

- NOTES:**
1. IN SOME CASES MAJOR GAS WILL BE NITROGEN IN PLACE OF ARGON. SEE GAS MIXER DATA SHEET FOR DETAILS.
 2. ALL DIMENSIONS IN INCHES UNLESS OTHERWISE SPECIFIED.

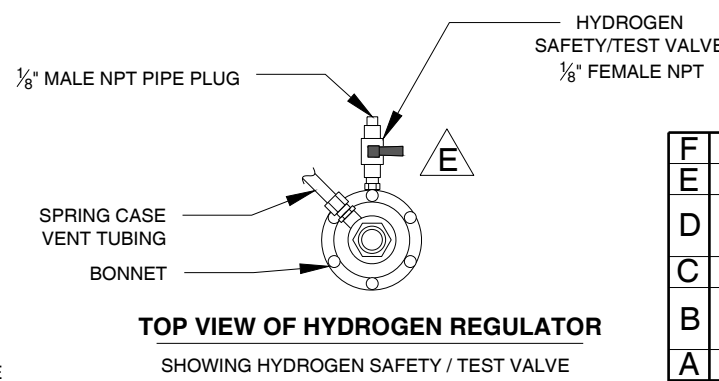
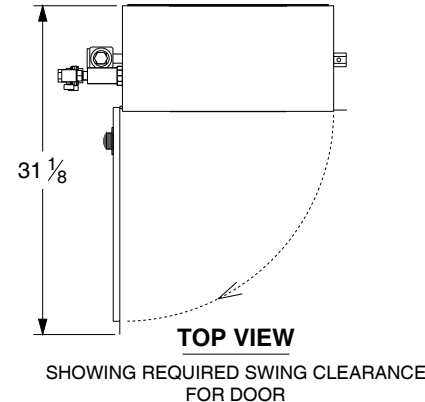

| REVISIONS | BY | DATE |
|-----------|-----|----------|
| F | | |
| E | GAR | 4-15-20 |
| D | GAR | 1-8-18 |
| C | DMR | 10-27-17 |
| B | DMR | 6-22-15 |
| A | DMR | 8-15-14 |

Thermco INSTRUMENT CORPORATION
LA PORTE, INDIANA USA

TITLE: **INSTRUCTION DRAWING FOR MODEL 8520 GAS MIXER**

| | |
|-----------------|------------|
| DATE: | 3-1-11 |
| SCALE: | N.T.S. |
| DRAWN BY: | JTM |
| APPROVED BY: | <i>JAR</i> |
| SUPERSEDES: | 2-11333 |
| DRAWING NUMBER: | 2-13308 |