

9/16" DIA. HOLE IN EACH OF SURGE TANK FEET

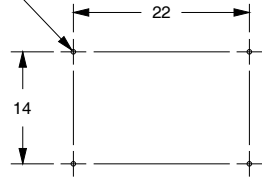

**SURGE TANK FEET HOLE PATTERN**

**VIEW SHOWING OPTIONAL MIXTURE SHUTOFF SOLENOID VALVE**

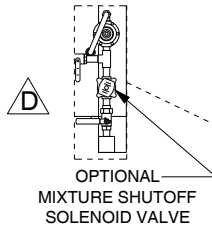

**VIEW SHOWING OPTIONAL MINOR GAS SHUTOFF SOLENOID VALVE**

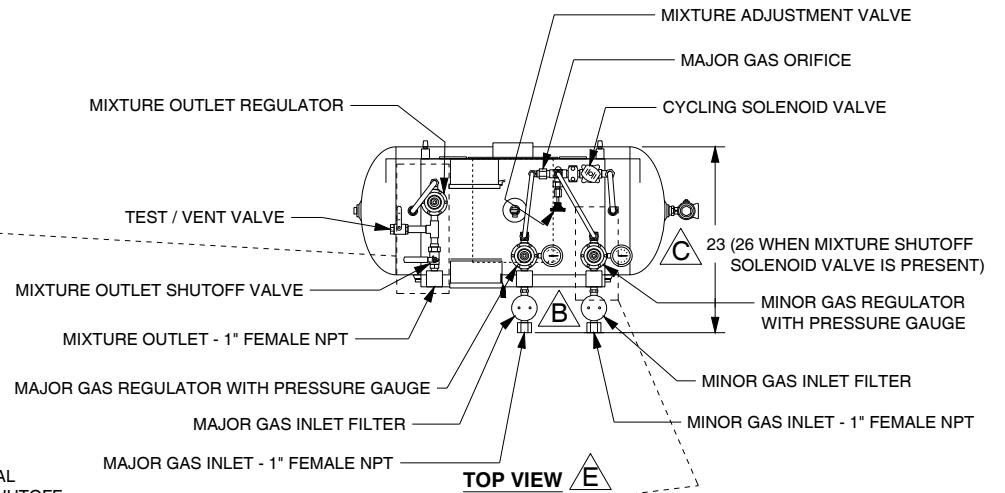
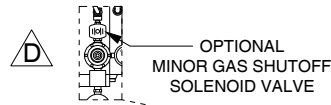

**TOP VIEW E**

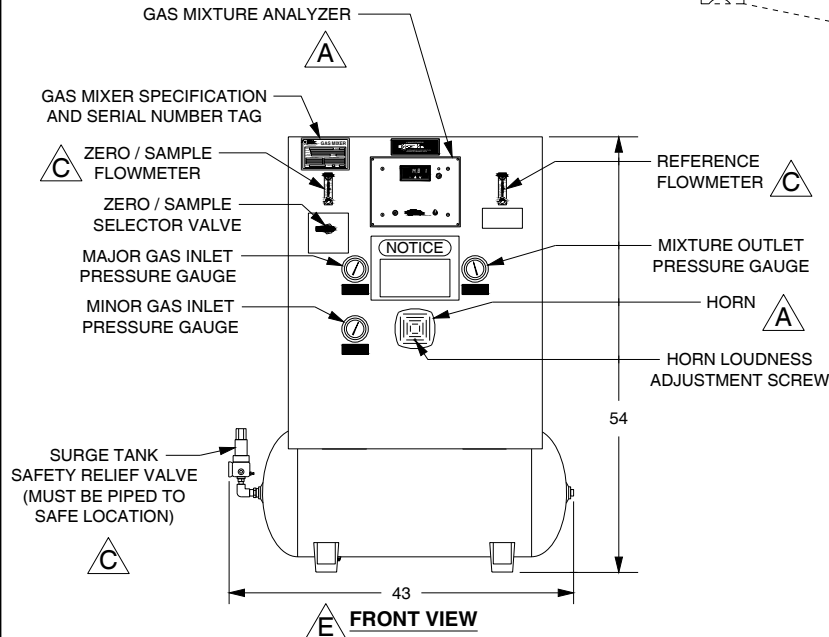

**FRONT VIEW E**

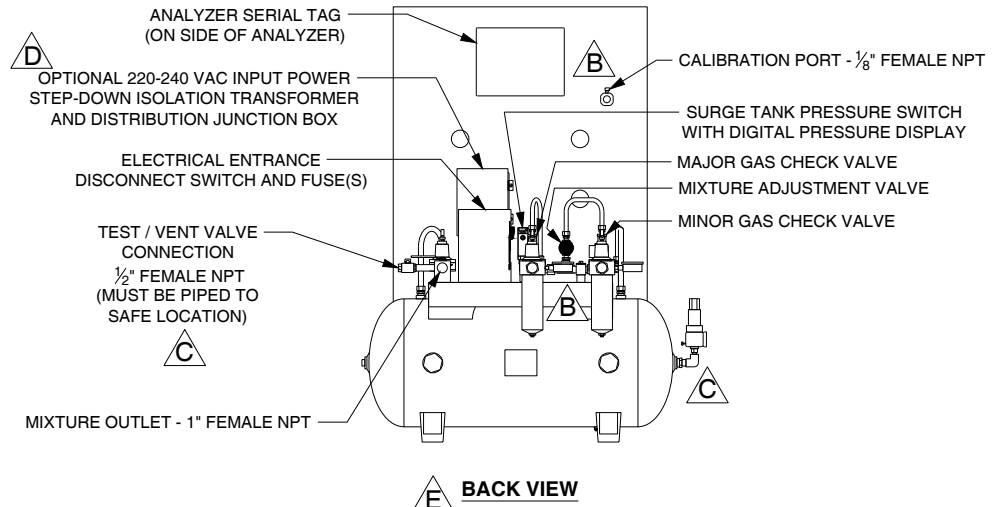

**BACK VIEW E**

REVISIONS	BY	DATE
E	DMR	3-7-17
D	GAR	3-3-14
C	GAR	1-16-12
B	GAR	4-12-10
A	DMR	6-30-08

DIMENSIONS ARE IN INCHES AND ARE APPROXIMATE.

**Thermco** INSTRUMENT CORPORATION  
LA PORTE, INDIANA USA

TITLE:  
**A** INSTRUCTION DRAWING FOR  
MODEL 6105 GAS MIXER  
WITH MODEL 9235 GAS ANALYZER

DATE:	12-16-02
SCALE:	N.T.S.
DRAWN BY:	BB
APPROVED BY:	<i>D M R</i>
SUPERSEDES:	
DRAWING NUMBER:	1-12163